

VHF HIGH BAND POWER AMPLIFIER MODULE: 1.5 kW PEAK SYNC

Contents:

Sec	Topic	Page
1	1.5 kW PA Module Introduction	1
2	6-way Splitter/Input Board	2
3	Individual RF Amplifiers	2
4	6-way Combiner/Output Board	3
5	VSWR Control Board	3
6	Adjustment of Bias Voltage	4
7	Low Power Sweep	5
8	Factory Test Fixture and Module Adjustments	7
9	Green LED Sensitivity Adjustment	7
10	VSWR Cutback Adjustment in Factory Test	8
11	Module Parts Lists channels 7-13	10

List of Figures:

Fig	Title	Drawing Reference
1	Sweep setup & response	text, page 6
2	Factory test fixture hookup	text, page 8
3	Module Assembly	40D1493 sht 2
4	Module Wiring Diagram	30C1302 sht 1
5	Module Input Board Assembly Diagram	40D1469 sht 1
6	Module Individual RF Amplifier Schematic	30C1305 sht 1
7	Module Output Board Assembly Diagram	40D1468 sht 4
8	Module VSWR Protection Board Assembly	20B1594 sht 1
	Module VSWR Protection Board Schematic	30C1418 sht 1

1. 1.5 kW HIGH BAND PA MODULE 40D1493G3:

Drawing references: 40D1493, 30C1302, 40D1469, 30C1305, 40D1468, 20B1594, 30C1418 (Figs 3 thru 8).

The 1.5 kW module consists of a frame, a front panel, two heatsinks, a 6-way power splitter, six 250 W FET amplifiers, a 6-way power combiner, a VSWR protection board, and power & I/O connectors. It is designed for 1.5 kW sync peak power output in High Band (174 - 216 MHz) NTSC television systems, and provides power gain of approximately 15 or 16 dB, with 1.5 kW peak sync visual or 900 W aural output. It is fully plug-in, incorporating protective circuitry for "excess VSWR" power cutback and to allow "hot plug-in" while the transmitter is operational.

Some statements made in this document are applicable to modules working in parallel in higher powered transmitters, so should be taken with less significance when referring to single modules, such as used in the TTS1000B 1 kW internally diplexed transmitter.

VHF HIGH BAND POWER AMPLIFIER MODULE: 1.5 kW PEAK SYNC

2. 6-Way Splitter/Input Board 40D1469G1: Refs: 30C1302 & 40D1469 (Figures 4 & 5).

The 6-Way power splitter receives its RF input signal as either the output from the IPA in the TTS1000B, or from one of the six outputs from the Visual Driver module in larger transmitters, and provides six input signals to integral input matching networks for the six FET amplifiers. The incoming signal is first split in three by a 3-way Wilkinson splitter, and the three resultant signals are split again by three 2-way Wilkinson splitters to provide the six outputs required. Terminations for the 3-way splitter are provided by R109, R110, and R111, with no reactive trimming necessary; and for the two-way splitters, terminations are R101, R103 and R105, again without reactive trimming. A built-in peak detector (CR102 and C147) is fed from a directional coupler on the input transmission line, to provide a sample of the input signal for module gain monitoring. R113 and R117 terminate the directional coupler, C115 provides an input match from the input connector to the input transmission line, and C119 is an RF bypass around the panel LED to discourage it from picking up RF.

Observe that in each pair of the six amplifier inputs, one of the pair is given a phase quadrature with a π section low pass network. Typical at amplifier #1 are C100, C101 which form a π network with the series inductance of a board trace, delaying the signal 90° to amplifier #1 with respect to amplifier #2. The two are therefore driven in quadrature, with #2 leading #1 by 90° . The other amplifier inputs are treated exactly the same way, with C104, C105 for pair #3 and #4, and with C108, C109 for pair #5 and #6. Even numbers lead odd numbers, when following left-to-right convention on reading the drawings as presented. After amplification, the proper in-phase relationship is restored by similar 90° delay components in the even numbered outputs, allowing the odd numbered ones to catch up.

3. Individual RF Amplifiers: Refs: 30C1302, 40D1469, 30C1305, & 40D1468 (Figs 4 thru 7).

Each of the six amplifiers consists of two, source grounded N-channel, insulated gate Field Effect Transistors (FETs) packaged in a single case, and operating in a push-pull configuration in class AB. These N-channel FETs are "enhancement mode" devices, so require a positive gate-to-source bias voltage on each gate to cause source-drain conduction. Quiescent Class AB idling bias current is set at 0.5 ampere for each half.

The gate voltage required to produce this idling current may vary between 2 and 5 V due to variances among FETs, and typically is 3 to 4 V. This gate voltage also is temperature sensitive, so temperature compensation is provided by R9, RT1, and R10, RT2. Gate bias is supplied through an adjustable voltage divider from the +39 V regulated bias rail. Resistors R1, R2, R3, R4 provide gate bias for one half of the amplifier; R5, R6, R7, R8 provide bias for the other half.

The input RF is applied to balun T1, L1 to provide two signal outputs 180° out of phase. These signals are stepped down to match the low input impedance of the device through a dual section, twin π network consisting of C1, C2, L2, L3, C7, and the device C_{GS} , and then applied to the gates. The gate impedance at the operating frequency is much lower than R3 and R6, so these resistors have no effect at RF.

R3 and R6 provide a DC path for bias, and provide loading at lower frequencies in order to assist in maintaining amplifier stability. The choice of C4 and C5 values, and their internal equivalent series inductances, also ensures effective bypassing at all frequencies.

The output matching π network, consisting of inductors L5 thru L10, and capacitances C12 thru C16, tunes out the FET drain capacitance and transforms the very low output impedance of the FET, upwards to a standard 50 ohms. The two 180° antiphase output signals are finally combined in balun T2, L11.

DC is applied to the drains through L4, L5 for the "A" half, and L6, L7 for the "B" half. L5 and L6 are also short sections of microstrip transmission line which transform the apparent RF impedances of L4 and L7 to higher values as seen by the FET. RF and lower frequencies are bypassed with C3, C8, C9, C6, C10, C11.

VHF HIGH BAND POWER AMPLIFIER MODULE: 1.5 kW PEAK SYNC

These groups of capacitors are selected in value and for their internal equivalent series inductances so that they will be an effective bypass at all frequencies of interest including video, to assist in maintaining stability. Towards this objective of stability, in addition to resonating with the device drain-to-drain capacitance at RF, inductor L9 places a heavy load on the FET output at low frequencies, where it behaves as a dead short.

4. 6-Way Combiner/Output Board 40D1468G1: Refs: 40D1468 & 30C1302 (Figs 7 & 4).

The six amplifier outputs are applied to three 2-way Wilkinson combiners after each even-numbered output is passed through a π network which introduces a 90° delay, to correct the quadrature condition imposed by the input splitter board. Typically, the π network for amplifier output #2 is C102, C103, and the series inductance of its board trace, while the π networks for #4 and #6 are their board traces combined with C106, C107 and C110, C111 respectively. The three outputs of these Wilkinson combiners are then combined by a 3-way Wilkinson combiner into one 50 ohm, 1.5 kW output. Terminations for the Wilkinson networks consist of R100, R102, and R104 for the three 2-way; and R106, R107, R108 for the 3-way combiner, which also requires reactive trimming from L100 thru L102 in order that the matching network can accommodate the bandwidth from channel 7 through 13.

There is one forward directional coupler, and one bi-directional coupler, located along the output microstrip transmission line matching section that connects the three way Wilkinson combiner node, to the module output RF connector. The output power level is 1.5 kW sync peak or 893 watts average CW.

The directional coupler feeds a BNC connector on the module front panel, and is used for output monitoring. The bi-directional coupler provides DC samples proportional to forward and reflected power to the VSWR protection board for monitoring module gain and VSWR protection. Terminations for these coupler line sections are provided by R114, R115, and R118; the RF samples for VSWR monitoring are peak detected by CR100, C112, and R112 for "forward" and by CR101, C113, and R116 for the "reflected" direction.

5. VSWR Control Board 20B1594G1: Refs: 20B1594 & 30C1418 (Figure 8).

The VSWR control board does several things: it provides regulated bias voltages to the FET power amplifier stages, provides hot-plug-in capability to protect the amplifier module when plugged into an operating transmitter, provides protection to the FETs against over-dissipation due to high VSWR, and it monitors the module RF power gain.

When the RF power amplifier module is plugged into a powered transmitter, the power supply connections are first made through the long contacts of the DC power connector and into VSWR board J1 pin 8, which allows the video bypass capacitors of all amplifiers to charge through the 10 Ω current limiting resistor R5. Without R5, assuming that each video bypass capacitor had an internal equivalent series resistance (ESR) of, say, 1 ohm, its charge current when plugged into a live transmitter would be $50 \text{ V} \div 1 \Omega = 50 \text{ A}$. This amount could seriously overstress all amplifier fuses if there were no current limiting. With R5 in place, the current limit provided is $50 \text{ V} \div 10 \Omega = 5 \text{ A}$, which is divided 12 ways as there are 12 fused circuits.

When the module is pushed home, the short high current contacts are now connected, and the module is able to operate normally. In normal operation the power supply enters J1 via pin 2, and is regulated to +39 VDC by series resistor R10 and zener diode VR1. Regulator U1 provides constant B+ voltage for op-amps U2, U3, U4, and the comparator reference voltages. When the module is first turned on (or plugged in) and U1 begins regulating, the charging current of C7 turns on Q1 which pulls the bias line low for a brief period of time. This provides a slow start for the module after DC power is applied.

VHF HIGH BAND POWER AMPLIFIER MODULE: 1.5 kW PEAK SYNC

5. VSWR Control Board 20B1594G1: Refs: 20B1594 & 30C1418 (Figure 8). (continued).

The overall RF system achieves precise VSWR sensing from the external RF detector boards discussed in other sections of this manual, but VSWR sensing is also provided in the module for its own safety.

In the higher powered transmitters using modules in parallel, one or more dead or disconnected modules or a fault in the six-way combiner or subsequent 3 dB coupler, causes a module output mismatch.

To the module, any mismatch appears as reflected power which is detected and applied thru pin 11 of J1 to comparator circuit U2B.

R21 sets the level at which VSWR protection begins. If the level of detected reflected power on pin 5 of U2B exceeds the control voltage set on pin 6, the output on pin 7 will go high. R22, C10, and CR1 provide a fast attack, slow release control voltage to Q2 when a high VSWR condition suddenly occurs. This will turn on Q2 which turns on Q4 which quickly reduces the bias applied to the power amplifier FETs; this reduced bias also reduces their gain and therefore their RF output and keeps their heat dissipation at safe levels.

The next two paragraphs apply to modules used in parallel in higher powered transmitters:

"When a module is plugged into an operating transmitter, the slow start circuitry consisting of C7 and Q1 will initially keep the module turned off. Power from the other modules working into the combiner will enter the module and be detected by the reflected power detector. This would prevent the module from ever operating properly, unless the VSWR circuit is momentarily over-ridden.

The circuit of U4 produces a pulse approximately 2 seconds after power is applied to the module. At power-up, pin 2 of U4 will be pulled high by C11. R26 charges this capacitor, and when the pin 2 voltage goes below the voltage on pin 3, the output of U4 will go high. A pulse whose duration is controlled by C9 and R18 will then be applied to pin 3 of U2A. U3B detects that the module is not producing forward power and that the reverse power is high. Under these conditions the output of U2A goes high, turning on Q3, momentarily disabling VSWR protection, and allowing the module to come on."

DC samples corresponding to forward power into and out of the module are applied to U3A pins 2 and 3 respectively. When pin 3 voltage is higher than that of pin 2, corresponding to "RF gain is okay" the comparator output U3A pin 1 is high, causing the green LED on the front panel of the module to light. The comparison threshold (ie. module gain is ok) is set by adjustment of R4.

Unwanted RF pickup due to the proximity of the front panel LED to the module input on the input splitter board is minimized by C149 at the LED, bypassing any RF directly to ground. The low pass filter section consisting of L1 and C5 on the VSWR board effectively discourages or prevents stray RF from upsetting the operation of U3A.

6. Adjustment of bias voltage to establish proper quiescent FET bias current:

Important: 50 Ω input and output terminations are necessary to achieve consistent results when testing modules. Termination is relatively simple for the PA modules.

1. Remove all fuses from the module to be tested. (There are 12 fuses in the 1.5 kW module).
2. Adjust all bias pots to maximum resistance, for minimum bias voltage. (Again, there are 12).
3. Use a clip lead to short the junction of C5, R6, and R7 to ground. This shuts off side B of the amplifier so it will not interfere (thru L9) with measurement of quiescent current from side A.

VHF HIGH BAND POWER AMPLIFIER MODULE: 1.5 kW PEAK SYNC

4. Terminate the RF input and output into a 50 Ω load.
5. Apply +50 VDC from a lab power supply, through an ammeter, to the B+ copper bus, and its negative to chassis. **Caution:** Observe polarity! This power supply should have variable current limit protection such that the current can be limited to approximately 1 amp for the bias adjustment.
6. Check the voltage on the bias terminals, it should be 39 V \pm 2 V. (The bias terminals are connected together via insulated bus wire).
7. Read the current drawn by the VSWR board and bias regulator. Next, install a fuse in side A (nearest the panel) of amplifier #1; adjust the corresponding bias pot for a 500 mA increase in the power supply current; this increase corresponds to an idling bias current of 0.5 A. Remove the fuse. Remove the side B bias short and place it on side A at the junction of C4, R2, and R3. Place the fuse in side B. Adjust the side B bias pot for 500 mA increase in power supply current.

Move the fuse to the remaining fuse holders, one at a time, and adjust each companion bias pot for a current increase of 500 mA, moving the bias short to the opposite side of each amplifier.
8. Install remaining fuses and remove the bias short after all bias adjustments have been made.

7. Low power sweep of 1.5 kW High Band amplifiers:

1. Connect the module to a sweep system, typically as shown in Figure 1 (page 6). The sweep generator should be adjusted to give a linear sweep from 160 to 240 MHz so that all of High Band or Band III is swept, with a small amount of out-of-band signal on both ends.
2. Connect the lab power supply +50 V to the copper B+ rail, and the negative to the chassis of the amplifier. The current should be limited to 7 or 8 A for this test. **Caution:** observe polarity! Ensure that terminations are in place so that the module works from 50 Ω and sees 50 Ω at all times. Be sure to connect a coaxial 20 dB attenuator to the amplifier output, in order to prevent possible damage to the sweep comparator.
3. With the power supply switched on, the current drawn should be not more than approximately 6 A (12 x 0.5 A) for the 1.5 kW PA module.

The swept in-band frequency response for all modules, should be essentially flat within \pm 1 dB as indicated in Figure 1, with PA module gain approximately 15 to 16 dB despite the error in Figure 1 which indicates sweep amplitude of 20 dB. We apologize; 16 \pm 1 dB is the correct amount.

Ignore those parts of the response that are out-of-band; many modules will show harmless peaks and valleys that appear to be of significantly greater observed amplitude than the in-band swept response. These are mostly due to the effects of the various reactances present in the circuit, including the "hidden" ones found in the FET's themselves, and should not affect the overall performance of the transmitter.

It is only natural that most of us will want to try and improve anything and everything we are able in the transmitter, and module swept frequency response may be judged to be no exception. However, before you succumb to temptation, we must caution you that getting any wideband amplifier sweep response to look "right" is a job not to be undertaken lightly. Adjusting sweep response is not a task that can be done easily or quickly. Even the replacement of an obviously damaged component may be cause for concern, because the positioning of surface mounted components can be critical, and a fully equipped RF laboratory is the only environment in which such an undertaking would have a reasonable chance for success.

VHF HIGH BAND POWER AMPLIFIER MODULE: 1.5 KW PEAK SYNC

7. Low power sweep of 1.5 kW High Band amplifiers:

If you believe the sweep response is bad enough that you think you should fix it, the chances are good that one or more defective components are present in the module, and you therefore have choices: Rent or buy a lab setup of RF test equipment, or return the module to LARCAN for repair and realignment. Many of our customers purchase extra modules for use as spares. This alternative of course minimizes the chances of operating with modules down, and therefore simplifies the return, repair, and realignment option.

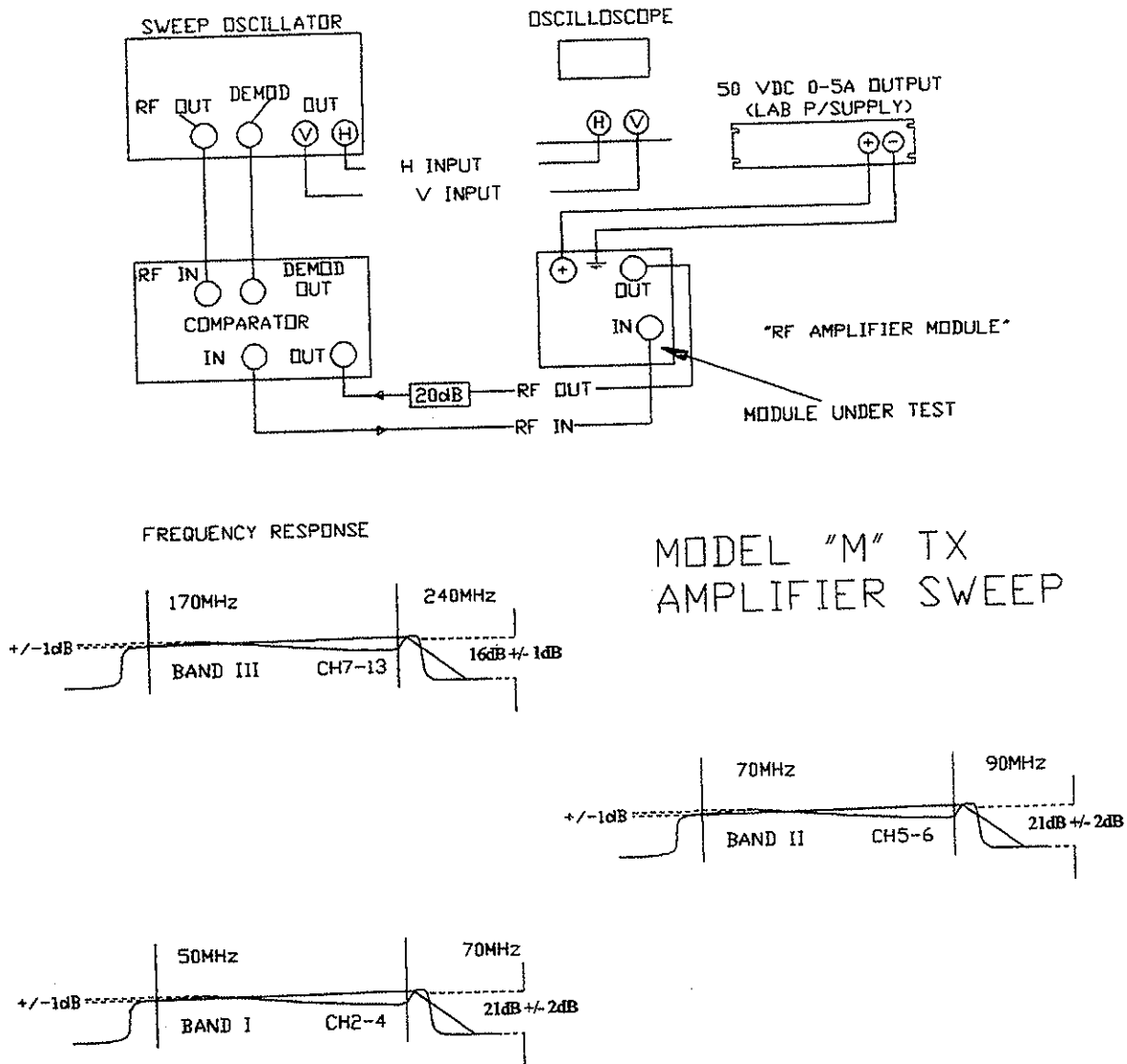

Figure 1: Module Sweep Response.

After the sweep tests are completed, the amplifier can be placed in the transmitter and powered up.

VHF HIGH BAND POWER AMPLIFIER MODULE: 1.5 kW PEAK SYNC

8. Factory Test Fixture and Module Adjustments:

In the LARCAN factory, the VSWR cutback and Green LED adjustments are carefully done with the PA module placed in a test fixture equipped with: a 500 cfm @ 1" SP cooling blower, a big DC power supply with adjustable output 0-60 V and current limit 0-90 A, two digital voltmeters, an ammeter shunt (50 mV at 50 amps) or a clamp-on DC current probe for one digital voltmeter, two in-line wattmeters and their sampling elements, a 1 kW dummy load, an adjustable gain (0-50W) RF driver amplifier, an exciter aural section or a signal generator (testing is done with CW), and suitable interconnecting cables.

Because the VSWR cutback and Green LED circuits have been adjusted at the factory, and are considered to be stable, they should not normally require any field adjustment. In fact, field adjustment is difficult because all the adjustment potentiometers are located on the BACK of the module; any adjustment is then impossible when the module is powered-up inside the transmitter. The Green LED adjustment, however, can be done incrementally with the module out of the transmitter, as described on the next page.

9. Green LED Sensitivity Adjustment: (Incremental, on-site field method):

One of the functions of the VSWR board is to monitor the overall gain of the 1.5 kW module. This VSWR board is located at the rear of the module, adjacent to the output RF connector. For the locations of the components on the board, please refer to Drawing 20B1594 (Assembly diagram of Figure 8).

Verify that all the 1.5 kW modules are in good working order, and then proceed as follows:

1. With all modules running at normal operating power, place AGC/MANUAL switch into the MANUAL position and adjust the exciter output power until the transmitter output power reads 110%.
2. Remove the module to be set up, and remove the two front fuses from it, in order to simulate a single FET package failure. Replace this "crippled" module in the transmitter, and apply a 50% APL staircase video signal to the transmitter.

The green LED should now be extinguished; if it is not, remove the module and adjust the blue potentiometer (R4) on the VSWR board clockwise, replace the module and try again, repeating until the LED is barely extinguished when the module is re-powered. (Early boards used a pot whose rotation was opposite and required to be turned counterclockwise to turn off the LED).

3. Replace the fuses so the module is again fully operational, and verify that the green LED is now fully lighted when the module is replaced in the transmitter and re-powered.

It is recommended that R4 be adjusted one half turn at a time, to establish a known reference point.

4. Place the AGC/MANUAL switch in the AGC position, and with the RAISE/LOWER switch, readjust the transmitter output power to 100%.
5. Similarly, the aural amplifier in externally duplexed transmitters may be adjusted in the same manner, but obviously there is no requirement for a video input signal.

Factory Adjustment of R4:

In the LARCAN factory test fixture, with an uncrippled good High Band module, the power supply voltage is simply lowered until the module output is reduced to 83% (5/6) of its initial power, and R4 is adjusted to barely extinguish the LED. This factory procedure depends on the fact that these FETs are constant current devices thus their gain is a linear function of the supply voltage.

VHF HIGH BAND POWER AMPLIFIER MODULE: 1.5 KW PEAK SYNC

9. Green LED Sensitivity Adjustment: (Incremental, on-site field method): (continued).

Our final test technicians use the incremental method if they find the LED setting is incorrect during their final transmitter tests, but they depend on the fixture method of setting that is done during module test, to establish their R4 starting point.

10. VSWR Cutback Adjustment in optional test fixture:

CAUTION: Adjustment of the VSWR cutback potentiometer R21 should only be attempted with the module in a properly configured test fixture, because it must be adjusted with RF drive, and at full power.

The VSWR board is located on the BACK of the module, and because the 6-way output combiner is located behind the modules and is essential to the transmitter operation, it is impossible to reach R21 when the module is in the transmitter.

If a test fixture is not available, a better course of action is simply to return the module to LARCAN.

Procedure for Adjustment in Optional Test Fixture:

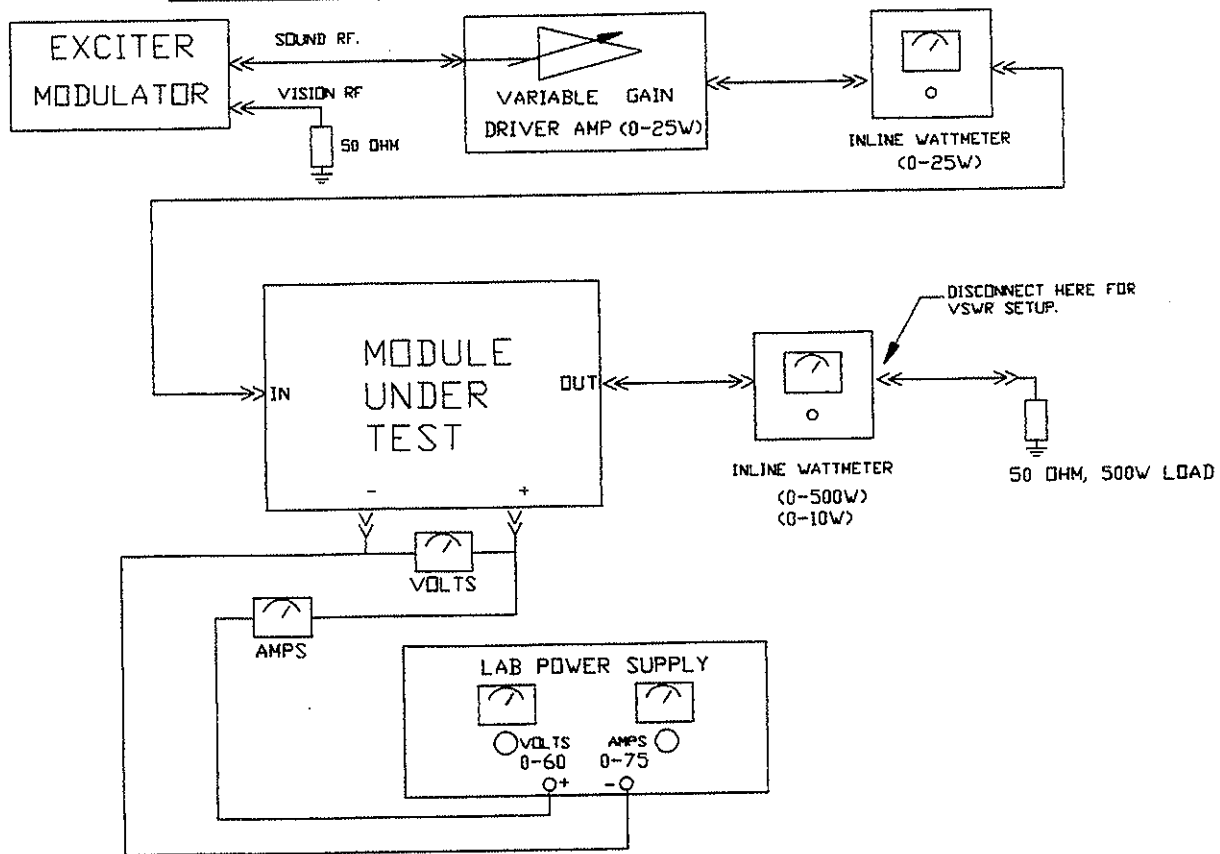

Figure 2: Test Fixture (Option) Hookup.

When a test fixture is available, use the exciter aural section as a CW generator, make connections per Figure 2 above, and do this:

VHF HIGH BAND POWER AMPLIFIER MODULE: 1.5 kW PEAK SYNC

Start with everything (except the exciter) turned OFF, and with the driver RF gain and the power supply controls turned down to minimum.

2. Place the module in the test fixture, start the blower, and ensure that air flows through the heatsink. Connect input, output, and DC cables. BE SURE THERE IS NO RF INPUT TO THE MODULE.
3. Switch the power supply ON, advance the power supply current limit control to about 10 A, and watch the output in-line RF wattmeter with its most sensitive sampling element in place, while increasing the power supply voltage gradually to 50 V.

If RF is observed, STOP right there! RF indicates instability in the amplifier which must be investigated and corrected. A spectrum analyzer, if available, is a much more sensitive instrument for the detection of stray RF, but care must be taken that the input of the analyzer is protected from being damaged by too-high RF levels.

4. If RF was not observed during step 3, change the output in-line RF wattmeter sampling element to 1000 W full scale. Increase the power supply current limit to maximum, increase the voltage to 50 V, turn on the aural section of the exciter, and gradually advance the RF gain control of the driver amplifier until the module output RF reads 1000 W. This CW power level is a convenient amount that is chosen because RF wattmeters are most accurate at full scale, and it is only about 0.5 dB higher than the 893 W average power contained in a 1.5 kW sync peak visual signal at black level.
5. Observe the DC input voltage and current. Their product is the DC input power. The RF output power divided by the DC input power and multiplied by 100 is defined as the efficiency of the module. Typically at 1000 W output CW, the efficiency will be around 40%. Observe the RF input power. It should be no more than 35 to 40 watts. The module gain in dB is 10 times the logarithm of the ratio (P_o/P_i) and is typically around 15 or 16 dB.
6. Reduce the RF gain to read 400 W at the module output. Adjust the power supply current control to begin limiting at this RF level. This reduces the probability of damage to the FETs while subsequent adjustments of VSWR cutback are being made.
7. Reduce the RF gain to zero and disconnect the dummy load cable from the output RF wattmeter. This places an extreme output mismatch on the module. (The output RF wattmeter must remain connected to the module). Gradually increase the RF drive until the output wattmeter reads maximum, but avoid increasing input power to more than 50 W.
8. Adjust R21 until the output RF power decreases to 300 W. For the module, this represents an extremely high VSWR. Accuracy is not an issue; the objective here is simply to get an R21 cutback setting that will save the FETs from over-dissipation when high VSWR is seen by the module such as in the event of a companion module failure. (The output metering circuits in the transmitter respond accurately to pre-set VSWR seen in the external RF system).
9. Adjust the RF input to the module, until the original input RF power of about 25 to 40 W is reached. Gradually increase the power supply current limit. The unterminated RF output from the module should not exceed 300 W under any circumstances.
10. Shut off the RF drive, and re-terminate the module. Apply RF drive again, and increase the power supply current limit to maximum. The module operating conditions should be the same as in step 5; i.e. output should be 1000 W, and the input drive between 20 and 35 W.
11. Shut off the RF drive and the power supply. Disconnect the module, and reinstall it in the transmitter. Restore transmitter connections to the exciter if it was used to generate the CW signal for the RF driver amplifier in the fixture.

VHF HIGH BAND POWER AMPLIFIER MODULE: 1.5 KW PEAK SYNC

To set green LED using test fixture: gradually decrease the power supply voltage until the module output power is 830 W, corresponding to a failure of one of the six push-pull amplifiers, and adjust R4 to barely extinguish the green LED front panel indicator. Restore the supply to 50 V and observe that the LED once again operates at full brightness.

This completes the adjustments that are possible to be made on the module. Of course, if the test fixture is available, the sweep response can be measured, and bias settings can be done as well; the same basic technique applies, as described in Sections 6 and 7 above.

The hookup of the optional test fixture, is shown on page 8.

Cable lengths are not considered to be critical; for your information, the LARCAN factory test fixture uses a straight reducing adapter (from module output to type N), followed by a right angle type N adapter between the module output reducer and the RF wattmeter input. (There is no cable used; the total distance through the connector combination is about 10 cm from the module output to the wattmeter input). Approximately 60 cm of Teflon dielectric coax cable is connected between the output connector of the wattmeter and the 1000 W dummy load.

Our test signal used for High Band comes from a lab signal generator at about 190 MHz. Of course, if your CW comes from the aural output of your exciter, then the frequency naturally will be on your operating channel, which is all that is really necessary.

In all fairness, we must state that although a test fixture can be built by station technicians, it will not be a cheap nor simple venture due to the requirement for a variable gain RF amplifier (which will require the expenditure of much more time than many of us would care to admit) and for a high current adjustable power supply, both of which can represent significant expenditures of resources.

LARCAN would be pleased to quote on the supply of a suitable test fixture, if desired, or we can provide the information for you to build your own. Many of our customers have evaluated their various alternatives and have chosen to simply purchase extra PA modules for spares to be used as required. For corporate owners having several High Band stations, this can represent an especially attractive alternative.

11. Parts Lists for High Band 1.5 kW PA Module:

LARCAN INC.
Parts List

Level	Parent No.	Description	Quantity
0	MODEL NO.	TRANSMITTER CH7-13	1 EA
1	CABINET NO.	CABINET ASSEMBLY FOR CH7-13	1 EA
2	HOUSING NO.	MODULE HOUSING ASSEMBLY FOR CH7-13	1 EA
3	40D1493G3	1.5KW MODULE ASM CH7-13 R-9	1 EA

Symbol	Part No.	Description	Quantity
	40D1493P1	ASSEMBLY DRAWING	EA
	30C1192G6	FRONT PNL ASM 1.5KW PWR AMP R-6	1 EA
	10A1270G1	DC CONNECTOR ASM MALE R-3	1 EA
	10A1296G1	PCB ASM & RF CONNECTOR R-4	1 EA
	20B1594G1	PCB ASM VSWR CONTROL R-9	1 EA

VHF HIGH BAND POWER AMPLIFIER MODULE: 1.5 KW PEAK SYNC

3	40D1493G3	1.5KW MODULE ASM CH7-13	R-9	1 EA
Symbol	Part No.	Description		Quantity
	40D1468G1	PCB ASSY OUTPUT CH7-13	R-15	1 EA
	40D1469G1	PCB ASSY INPUT CH7-13	R-14	1 EA
	40D1467P1	FRONT HEATSINK MODIFIED	R-16	1 EA
	40D1467P2	REAR HEATSINK MODIFIED	R-15	1 EA
	20B1128P1	MODULE SUPPORT & SLIDE	R-8	1 EA
	20B1128P2	MODULE SUPPORT & SLIDE	R-8	1 EA
	BJ120	BULKHEAD JACK (INPUT)		1 EA
	10A1154P1	INPUT CONNECTOR MOUNTING PLATE	R-2	2 EA
	8483 (ALUM)	SPACER #4 SCREW		2 EA
	10A1159P1	DC CONNECTOR MOUNTING BLOCK	R-4	1 EA
	10A1159P2	DC CONNECTOR MOUNTING BLOCK	R-4	1 EA
	30C1458P1	COVER	R-0	2 EA
	20B1600P1	HARNES		1 EA
	CE100F24-11	END CONNECTOR		1 EA
	EC100F-11	COVER		1 EA
	10A1550P1	SPACER M/F #4/#4		4 EA
	20B1407P1	BUS BAR	R-1	1 EA
	SRF3943-2	TRANSISTOR FET N-ch Dual		6 EA
	10A1564P1	TRANSISTOR CLAMP	R-3	6 EA
	10A1566P1	PRESSURE PLATE CLAMP	R-3	6 EA
	10A1623P1	INDUCTOR BRIDGE		6 EA
	312007	FUSE 7A 250V <FAST>		12 EA

LARCAN INC.
Parts List

Level	Parent No.	Description	Quantity
3	40D1493G3	1.5KW MODULE ASM CH7-13	1 EA
4	30C1192G6	FRONT PNL ASM 1.5KW PWR AMP	1 EA

Symbol	Part No.	Description	Quantity
	30C1192P6	ASSEMBLY DRAWING	EA
	40D1383P5	FRONT PANEL	1 EA
	2-G	GUIDE stainless steel	2 EA
	2-L	LATCH stainless steel	2 EA
	2-R-113	RIVET	2 EA
	2-W	WASHER stainless steel	2 EA
	415-2111-020200	HANDLE	1 EA
	559-0201-001	LED GREEN	1 EA
	UG-625B/U	RECEPTACLE BNC sub 31-236	1 EA

VHF HIGH BAND POWER AMPLIFIER MODULE: 1.5 KW PEAK SYNC

LARCAN INC.
Parts List

Level	Parent No.	Description	Quantity
3	40D1493G3	1.5KW MODULE ASM CH7-13 R-9	1 EA
4	10A1270G1	DC CONNECTOR ASM MALE R-3	1 EA

Symbol	Part No.	Description	Quantity
	10A1270P1	DC CONNECTOR ASSEMBLY DWG	EA
	10A1177P1	GROUNDING BRACKET R-6	1 EA
	10A1269P1	LOCKING RAIL R-2	2 EA
	1410-14	TERMINAL LUG	1 EA
	EC-002	END CAPS	2 EA
	FP-2-04	PIN MODULE F	1 EA
	KP-000	CONNECTOR MODULAR	2 EA

LARCAN INC.
Parts List

Level	Parent No.	Description	Quantity
3	40D1493G3	1.5KW MODULE ASM CH7-13 R-9	1 EA
4	10A1296G1	PCB ASM & RF CONNECTOR R-4	1 EA

Symbol	Part No.	Description	Quantity
-	10A1296P1	ASSEMBLY DRAWING	EA
-	10A1298P1	CONNECTOR KEY	EA
-	10A1295P1	PCB RF CONNECTOR R-5	1 EA
-	10A1399P1	PCB INSULATOR BOARD R-3	1 EA
-	20B1332G1	CONNECTOR ASM purchase complete R-2	1 EA
-	663-110	SOLDER LUG ZIERICK	1 EA
-	B1570-B-3/32-12	SPACER	1 EA
-	HN-9B	NUT BRASS 1/4" A/F	1 EA

VHF HIGH BAND POWER AMPLIFIER MODULE: 1.5 KW PEAK SYNC

LARCAN INC.
Parts List

Level	Parent No.	Description	Quantity
3	40D1493G3	1.5KW MODULE ASM CH7-13 R-9	1 EA
4	20B1594G1	PCB ASM VSWR CONTROL R-9	1 EA
Symbol	Part No.	Description	Quantity
-	20B1594	ASM/PATTERN/SILKSCRN/SOLDMSK	EA
-	30C1418	SCHEMATIC R-6	EA
-	20B1594P1	PCB VSWR CONTROL R-2	1 EA
-	508-AG11D	IC SOCKET 8 PIN	3 EA
-	B1570-B-1/4-12	SPACER	4 EA
-	MLSS100-11	LOCKING HEADER	1 EA
C1	630-09472	CAP 4700p 100V CERAMIC	1 EA
C2	630-09472	CAP 4700p 100V CERAMIC	1 EA
C3	030-38108	CAP 1μ 63V ELECT	1 EA
C4	630-09472	CAP 4700p 100V CERAMIC	1 EA
C5	630-09472	CAP 4700p 100V CERAMIC	1 EA
C6	030-38108	CAP 1μ 63V ELECT	1 EA
C7	030-36229	CAP 22μ 25V ELECT	1 EA
C8	370-11334	CAP 0.33μ 63V FILM	1 EA
C9	370-11334	CAP 0.33μ 63V FILM	1 EA
C10	030-36109	CAP 10μ 25V ELECT	1 EA
C11	370-11334	CAP 0.33μ 63V FILM	1 EA
CR1	1N4001	DIODE GEN PURP	1 EA
L1	10A212P1	COIL 7t ¼"ID, #20 R-6	1 EA
Q1	MPS8098	TRANSISTOR NPN AMP	1 EA
Q2	MPS8098	TRANSISTOR NPN AMP	1 EA
Q3	MPS8098	TRANSISTOR NPN AMP	1 EA
Q4	MJE350	TRANSISTOR PNP SWITCHING	1 EA
R1	3R152P513J	RES ¼W 5% 51k	1 EA
R2	3R152P104J	RES ¼W 5% 100k	1 EA
R3	3R152P101J	RES ¼W 5% 100Ω	1 EA
R4	3299W-1-104	POT 100k	1 EA
R5	2322 191 31009	RES 1.6W 5% 10Ω	1 EA
R6	PR37J 470 OHM	RES 1W 5% 470Ω	1 EA
R7	3R152P106J	RES ¼W 5% 10M	1 EA
R8	3R152P103J	RES ¼W 5% 10k	1 EA
R9	3R152P101J	RES ¼W 5% 100Ω	1 EA
R10	CW5-500 OHMS	RES 5W 5% 500Ω	1 EA
R11	3R152P203J	RES ¼W 5% 20k	1 EA
R12	3R152P104J	RES ¼W 5% 100k	1 EA
R13	3R152P202J	RES ¼W 5% 2k	1 EA
R14	3R152P103J	RES ¼W 5% 10k	1 EA
R15	3R152P473J	RES ¼W 5% 47k	1 EA

VHF HIGH BAND POWER AMPLIFIER MODULE: 1.5 KW PEAK SYNC

Symbol	Part No.	Description	Quantity
4	20B1594G1	PCB ASM VSWR CONTROL R-9	1 EA
R16	3R152P473J	RES 1/4W 5% 47k	1 EA
R17	3R152P103J	RES 1/4W 5% 10k	1 EA
R18	3R152P104J	RES 1/4W 5% 100k	1 EA
R19	3R152P202J	RES 1/4W 5% 2k	1 EA
R20	3R152P102J	RES 1/4W 5% 1k	1 EA
R21	3329H-1-102	POT 1k	1 EA
R22	3R152P472J	RES 1/4W 5% 4.7k	1 EA
R23	3R152P472J	RES 1/4W 5% 4.7k	1 EA
R24	3R152P392J	RES 1/4W 5% 3.9k	1 EA
R25	3R152P101J	RES 1/4W 5% 100Ω	1 EA
R26	3R152P914J	RES 1/4W 5% 910k	1 EA
R27	3R152P103J	RES 1/4W 5% 10k	1 EA
R28	3R152P102J	RES 1/4W 5% 1k	1 EA
R29	3R152P204J	RES 1/4W 5% 200k	1 EA
R30	3R152P202J	RES 1/4W 5% 2k	1 EA
U1	MC78L24CP	IC 24 VOLT REG	1 EA
U2	LM358N	IC OP AMP	1 EA
U3	LM358N	IC OP AMP	1 EA
U4	LM358N	IC OP AMP	1 EA
VR1	1N5366B	DIODE ZENER 39V	1 EA
LARCAN INC. Parts List			
Level	Parent No.	Description	Quantity
3	40D1493G3	1.5KW MODULE ASM CH7-13 R-9	1 EA
4	40D1468G1	PCB ASSY OUTPUT CH7-13 R-15	1 EA
Symbol	Part No.	Description	Quantity
	40D1468	PATTERN/ASM DWG	EA
	30C1305	SCHEMATIC 1 R-7	EA
	30C1302	SCHEMATIC 2	EA
	40D1468P1	PCB OUTPUT COMBINER R-4	1 EA
	100058	FUSE CLIP	12 EA
	UT-85C TP 50	COAX CABLE 50 OHM TIN PLATED for T2	4 FT
C3	5051-3474K	CAP 0.47μ 100V FILM Siemens	6 EA
C6	5051-3474K	CAP 0.47μ 100V FILM Siemens	6 EA
C8	100B-102-JP100X	CAP 1000p 100V CHIP	6 EA
C9	2222-119-28479	CAP 47μ 63V ELECT	6 EA
C10	100B-102-JP100X	CAP 1000p 100V CHIP	6 EA
C11	2222-119-28479	CAP 47μ 63V ELECT	6 EA
C12	175B-300-JMS500X	CAP 30p 500V CHIP	6 EA
C13	175B-270-JMS500X	CAP 27p 500V CHIP	6 EA
C14	175B-390-JP500X	CAP 39p 500V CHIP	6 EA
C15	175B-390-JP500X	CAP 39p 500V CHIP	6 EA
C16	100B-6R8-JP500X	CAP 6.8p 500V CHIP	6 EA

VHF HIGH BAND POWER AMPLIFIER MODULE: 1.5 KW PEAK SYNC

Symbol	Part No.	Description	Quantity
	40D1468G1	PCB ASSY OUTPUT CH7-13 R-15	1 EA
C102	100B-5R1-CP500X	CAP 5.1p 500V CHIP	1 EA
C103	100B-5R1-CP500X	CAP 5.1p 500V CHIP	1 EA
C106	100B-5R1-CP500X	CAP 5.1p 500V CHIP	1 EA
C107	100B-5R1-CP500X	CAP 5.1p 500V CHIP	1 EA
C110	100B-5R1-CP500X	CAP 5.1p 500V CHIP	1 EA
C111	100B-5R1-CP500X	CAP 5.1p 500V CHIP	1 EA
C112	200B-393-MP50X	CAP 39n 50V CHIP	1 EA
C113	200B-393-MP50X	CAP 39n 50V CHIP	1 EA
CR100	HP5082-2800	DIODE see ECG#503 or 1N5711	1 EA
CR101	HP5082-2800	DIODE see ECG#503 or 1N5711	1 EA
L4	1-3/16-3-CW-20	COIL 20B1627 2wt 20AWG 3/16 ID	6 EA
L7	1-3/16-3-CW-20	COIL 20B1627 2wt 20AWG 3/16 ID	6 EA
L9	10A1135P2	INDUCTOR	6 EA
L100	2-3/16-9-CW-20	COIL 20B1627 9t 20AWG 3/16 ID	1 EA
L101	2-3/16-9-CW-20	COIL 20B1627 9t 20AWG 3/16 ID	1 EA
L102	2-3/16-9-CW-20	COIL 20B1627 9t 20AWG 3/16 ID	1 EA
R100	PPR975-250-3-100	RES 250W 5% 100Ω	1 EA
R102	PPR975-250-3-100	RES 250W 5% 100Ω	1 EA
R104	PPR975-250-3-100	RES 250W 5% 100Ω	1 EA
R106	PPR975-250-3-150	RES 250W 5% 150Ω	1 EA
R107	PPR975-250-3-150	RES 250W 5% 150Ω	1 EA
R108	PPR975-250-3-150	RES 250W 5% 150Ω	1 EA
R112	9C12063A1100JL	RES 1/4W 5% 110Ω CHIP	1 EA
R114	PR37J 51 OHMS	RES 1.6W 5% 51Ω	1 EA
R115	PR37J 51 OHMS	RES 1.6W 5% 51Ω	1 EA
R116	9C12063A1100JL	RES 1/4W 5% 110Ω CHIP	1 EA
R118	PR37J 51 OHMS	RES 1.6W 5% 51Ω	1 EA
T2	UT-85	BALUN make from UT-85C cable	6 EA

LARCAN INC.
Parts List

Level	Parent No.	Description	Quantity
3	40D1493G3	1.5KW MODULE ASM CH7-13 R-9	1 EA
4	40D1469G1	PCB ASM INPUT CH7-13 R-14	1 EA

Symbol	Part No.	Description	Quantity
	40D1469	ASSEMBLY DRAWING R-7.4	EA
	30C1305	SCHEMATIC 1 R-7	EA
	30C1302	SCHEMATIC 2	EA
	40D1469P1	PCB INPUT SPLITTER R-7.3	1 EA
	B1537-B-1/8-12	SPACER	7 EA
	100058	FUSE CLIP	12 EA
	UT-85C TP 50	CABLE COAX TIN PLATED	3 FT

VHF HIGH BAND POWER AMPLIFIER MODULE: 1.5 KW PEAK SYNC

Symbol	Part No.	Description	Quantity
4	40D1469G1	PCB ASM INPUT CH7-13 R-14	1 EA
C1	100B-330-JP500X	CAP 33p 500V CHIP	6 EA
C2	100B-330-JP500X	CAP 33p 500V CHIP	6 EA
C4	200B-393-MP50X	CAP 39n 50V CHIP	6 EA
C5	200B-393-MP50X	CAP 39n 50V CHIP	6 EA
C7	100B-680-JP500X	CAP 68p 500V CHIP	6 EA
C100	100B-5R1-CP500X	CAP 5.1p 500V CHIP	6 EA
C101	100B-5R1-CP500X	CAP 5.1p 500V CHIP	1 EA
C104	100B-5R1-CP500X	CAP 5.1p 500V CHIP	1 EA
C105	100B-5R1-CP500X	CAP 5.1p 500V CHIP	1 EA
C108	100B-5R1-CP500X	CAP 5.1p 500V CHIP	1 EA
C109	100B-5R1-CP500X	CAP 5.1p 500V CHIP	1 EA
C114	200B-393-MP50X	CAP 39n 50V CHIP	1 EA
C115	100B-3R3-CP500X	CAP 3.3p 500V CHIP	1 EA
C119	200B-393-MP50X	CAP 39n 50V CHIP	1 EA
C120	100B-102-JP100X	CAP 1000p 100V CHIP	1 EA
CR102	HP5082-2800	DIODE see ECG#503 or 1N5711	1 EA
R1	9C12063A2702JL	RES 1/4W 5% 27k CHIP	1 EA
R2	3269W-001-104	POT 100k	6 EA
R3	SRF25HM10RJ	RES 1/2W 5% 10Ω sub 3R77P100J	6 EA
R4	3R152P472J	RES 1/4W 5% 4.7k	6 EA
R5	3R152P472J	RES 1/4W 5% 4.7k	6 EA
R6	SRF25HM10RJ	RES 1/2W 5% 10Ω sub 3R77P100J	6 EA
R7	3269W-001-104	POT 100k	6 EA
R8	9C12063A2702JL	RES 1/4W 5% 27k CHIP	6 EA
R9	9C12063A1502JL	RES 1/4W 5% 15k CHIP	6 EA
R10	9C12063A1502JL	RES 1/4W 5% 15k CHIP	6 EA
R101	PPR51520-3-100	RES 20W 5% 100Ω	1 EA
R103	PPR51520-3-100	RES 20W 5% 100Ω	1 EA
R105	PPR51520-3-100	RES 20W 5% 100Ω	1 EA
R109	PPR51520-3-150	RES 20W 5% 150Ω	1 EA
R110	PPR51520-3-150	RES 20W 5% 150Ω	1 EA
R111	PPR51520-3-150	RES 20W 5% 150Ω	1 EA
R113	9C12063A1100JL	RES 1/4W 5% 110Ω CHIP	1 EA
R117	9C12063A1100JL	RES 1/4W 5% 110Ω CHIP	1 EA
RT1	MSC154K	THERMISTOR 100k	6 EA
RT2	MSC154K	THERMISTOR 100k	6 EA
T1	UT-85	BALUN make from UT-85 cable	6 EA

** END OF PARTS LIST **

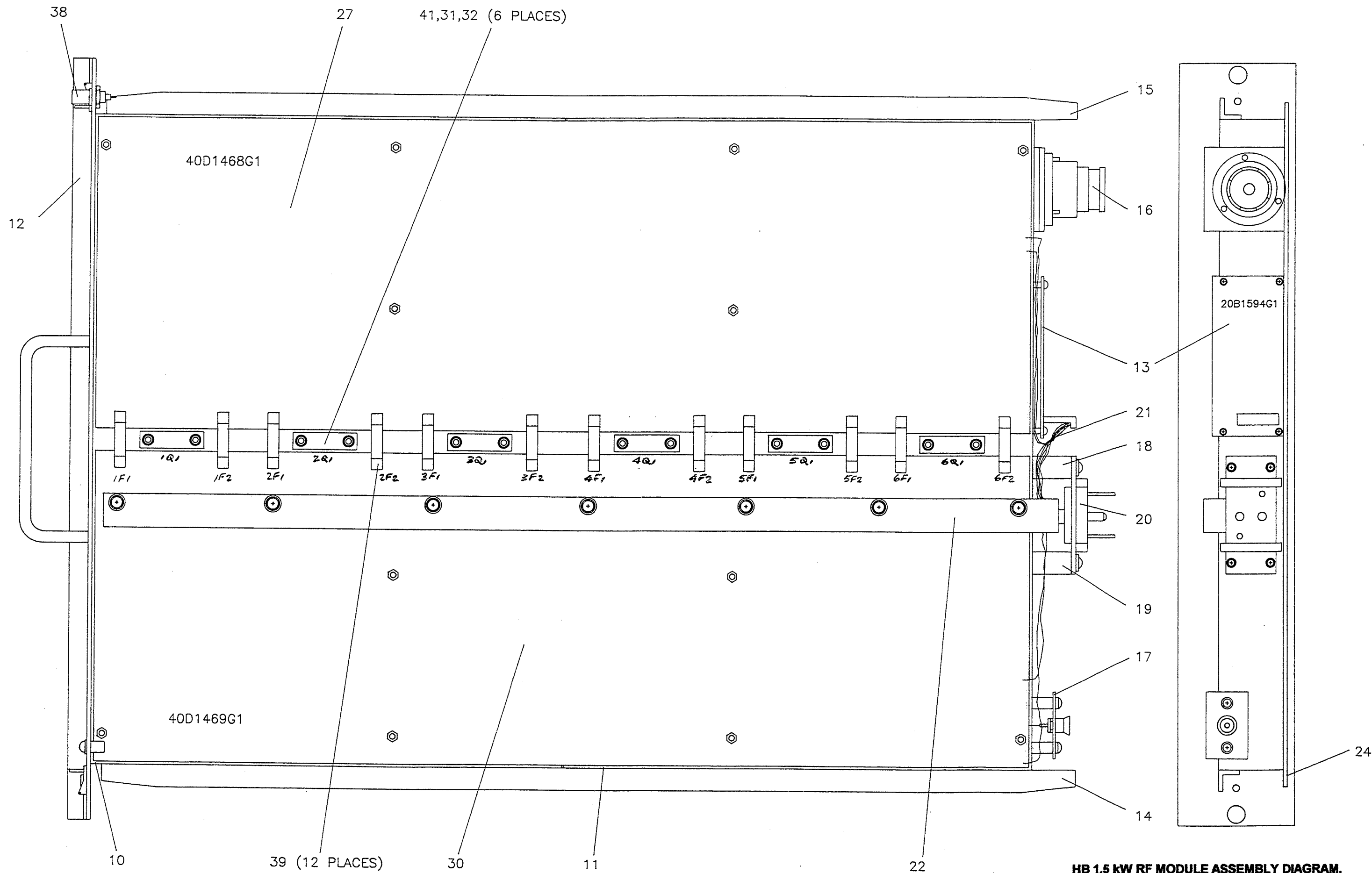

HB 1.5 kW RF MODULE ASSEMBLY DIAGRAM,
 Ref Dwg: 40D1493 sht 2 rev 0,

RS

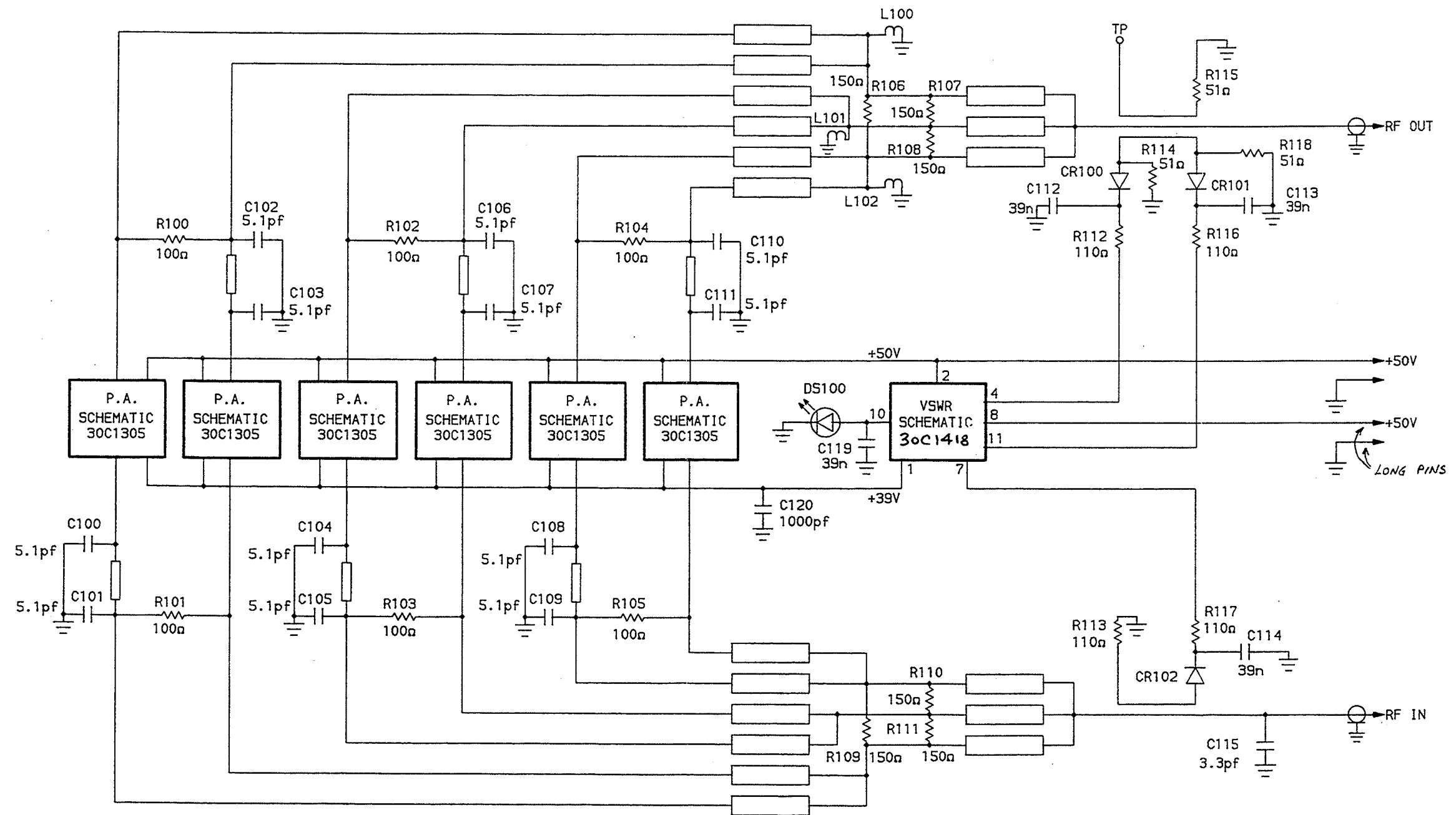

HB 1.5 kW RF MODULE WIRING DIAGRAM,
Ref Dwg: 30C1302 sht 1 rev 1,

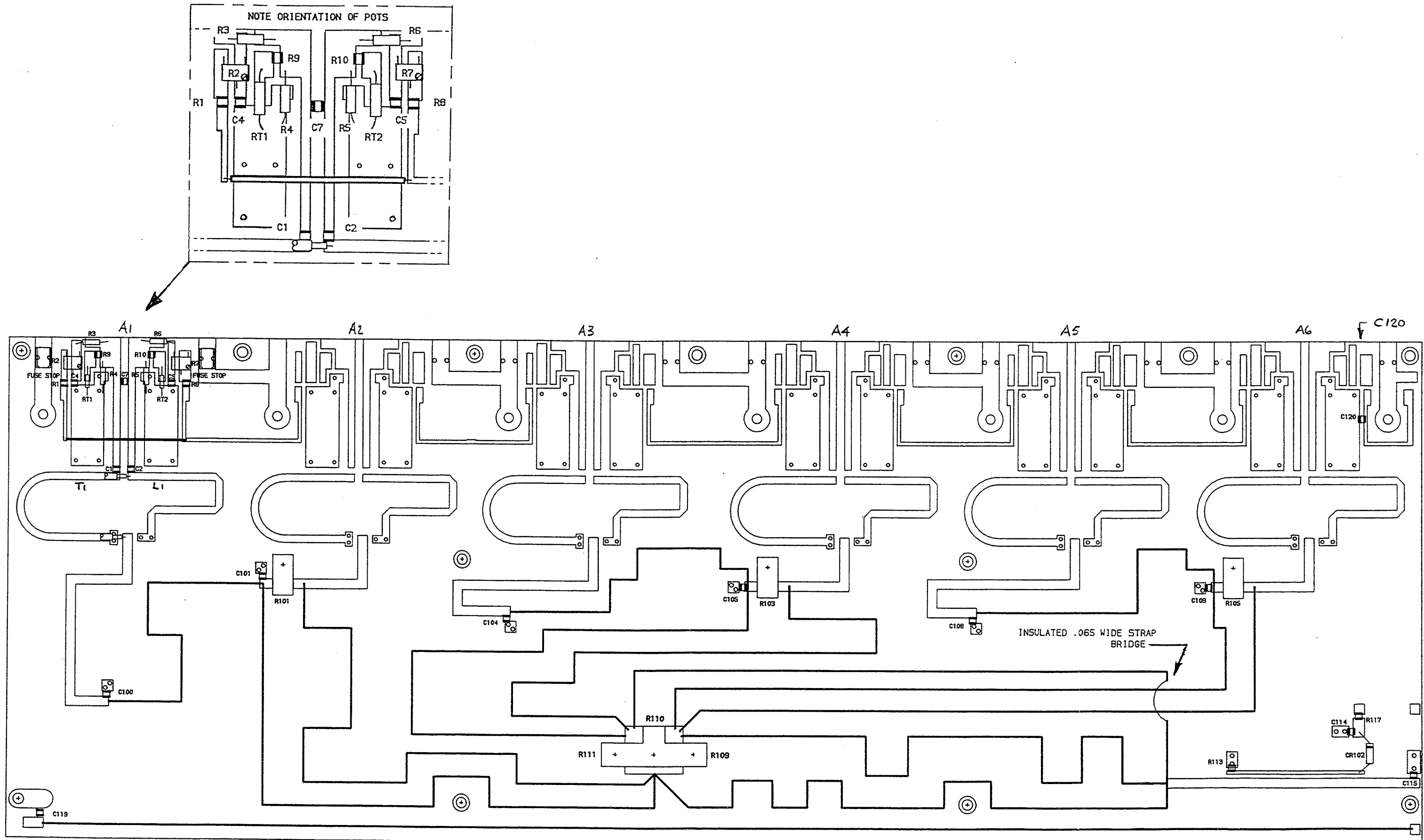

HB 1.5 KW RF MODULE INPUT BOARD ASSEMBLY DIAGRAM,
Ref Dwg: 40D1469 sht 1 rev 7.2,

K9

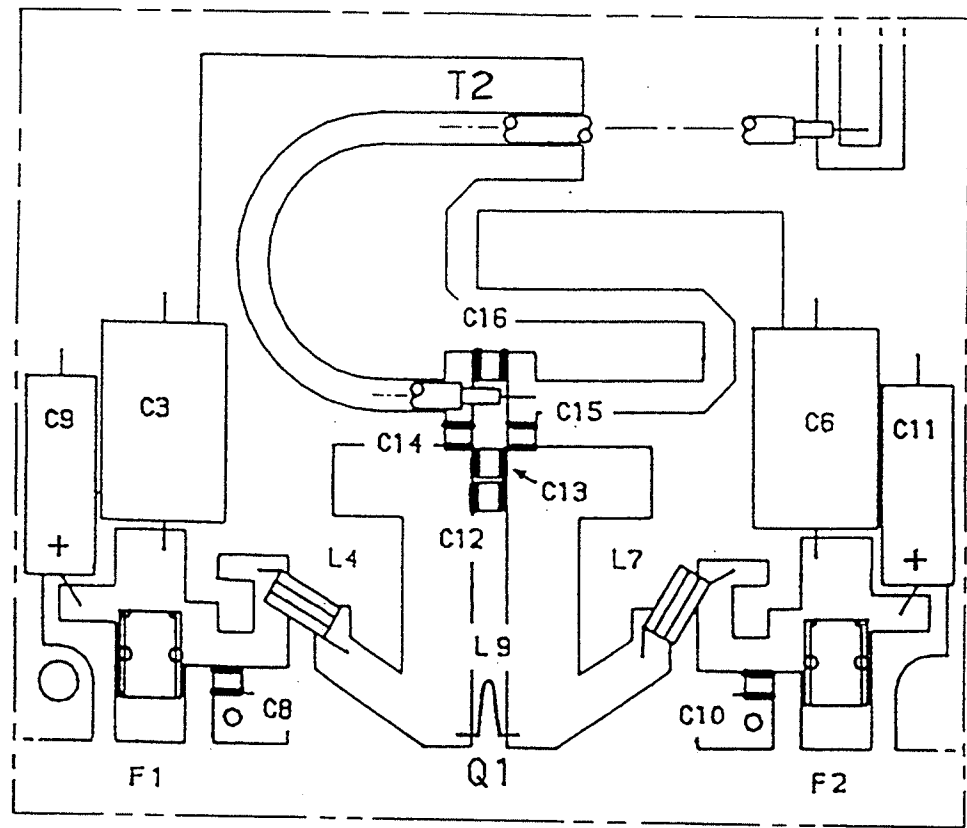

HB AMPLIFIER SINGLE STAGE:
OUTPUT COMPONENTS (from 40D1468)

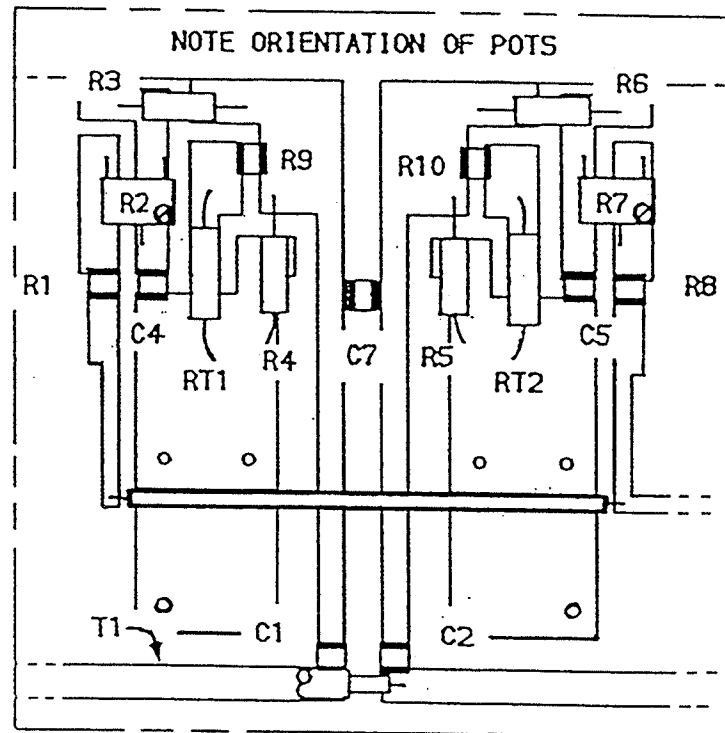

HB AMPLIFIER SINGLE STAGE:
INPUT COMPONENTS (from 40D1469)

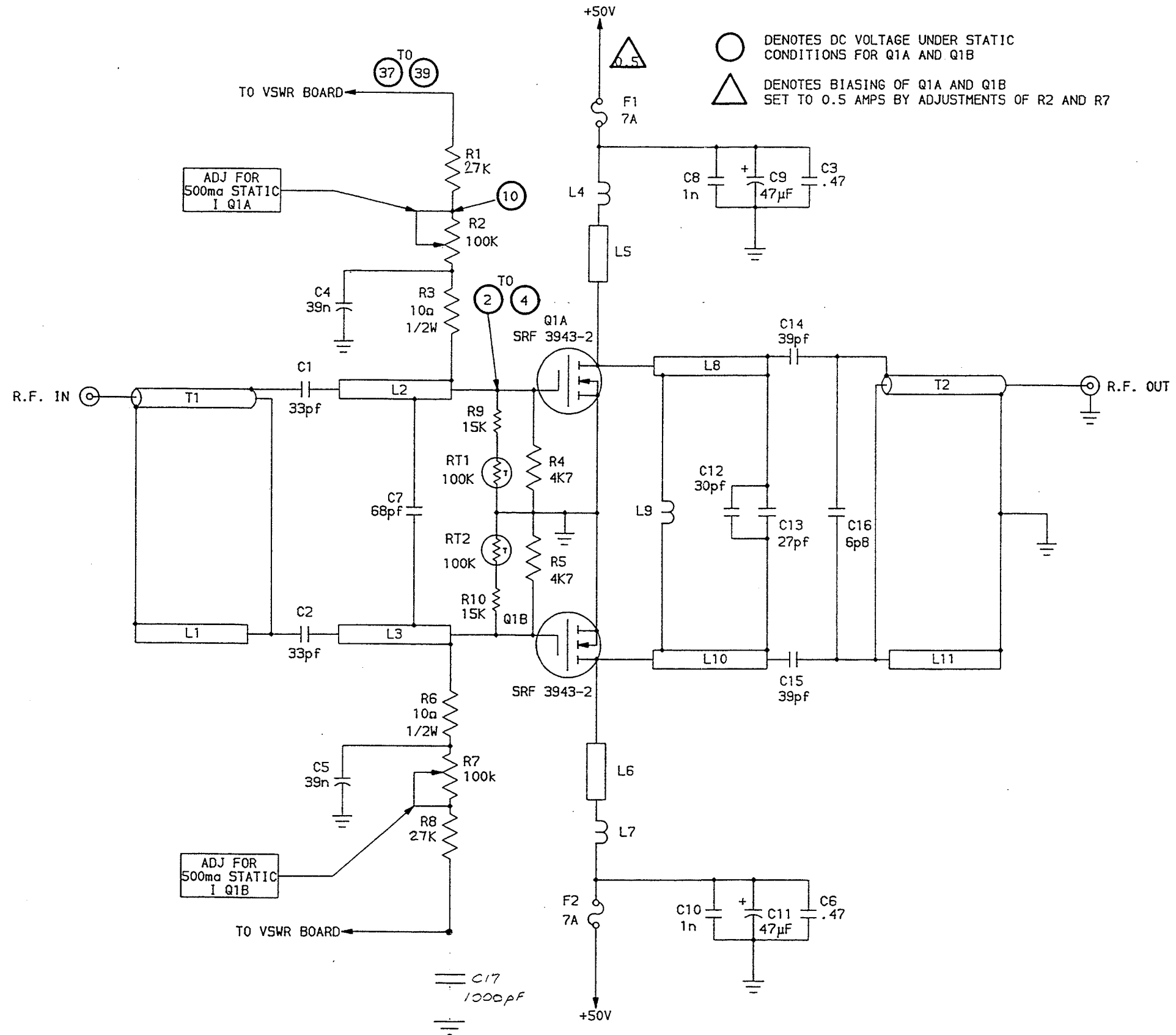

HB 1.5 kW RF MODULE INDIVIDUAL AMPLIFIER SCHEMATIC,
Ref Dwg: 30C1305 sht 1 rev 7,

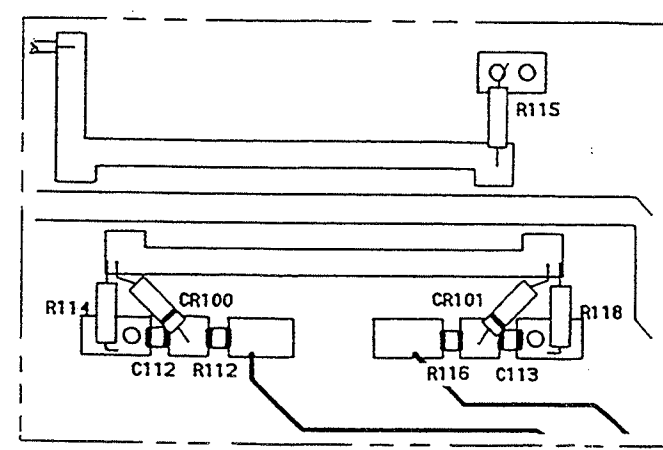
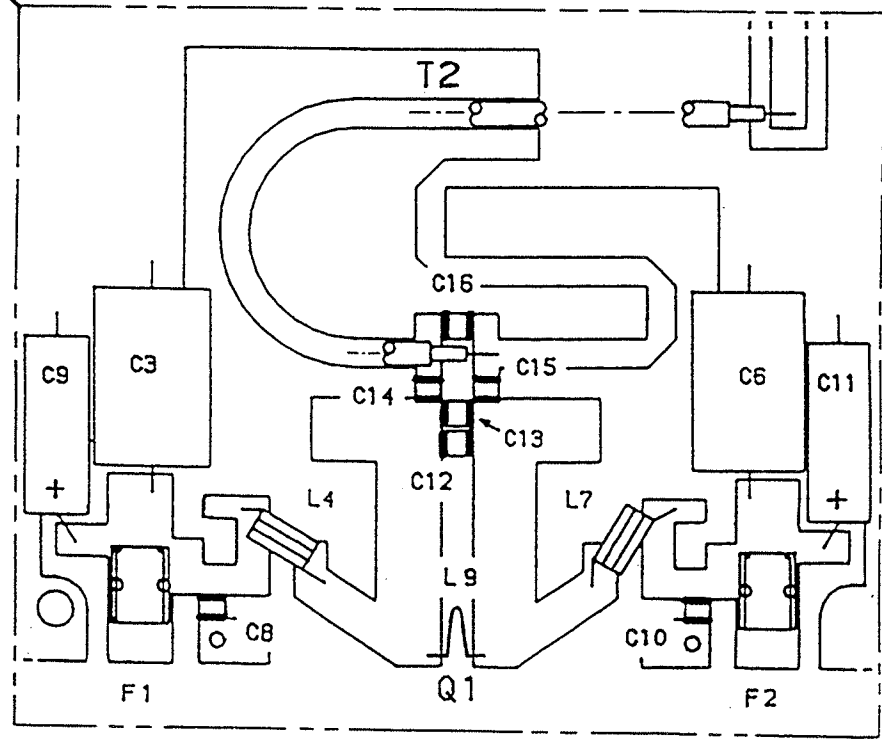
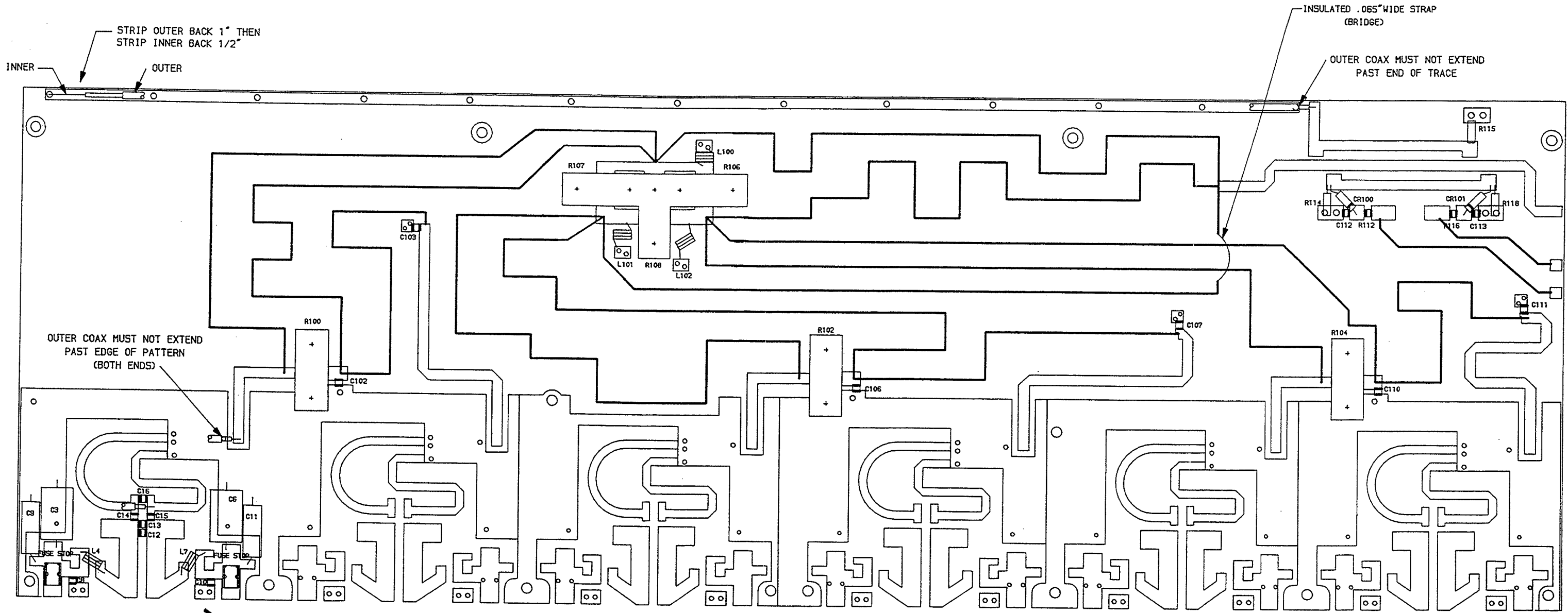

HB 1.5 kW RF MODULE OUTPUT BOARD ASSEMBLY DIAGRAM,
 Ref Dwg: 40D1468 sht 1 rev 6,

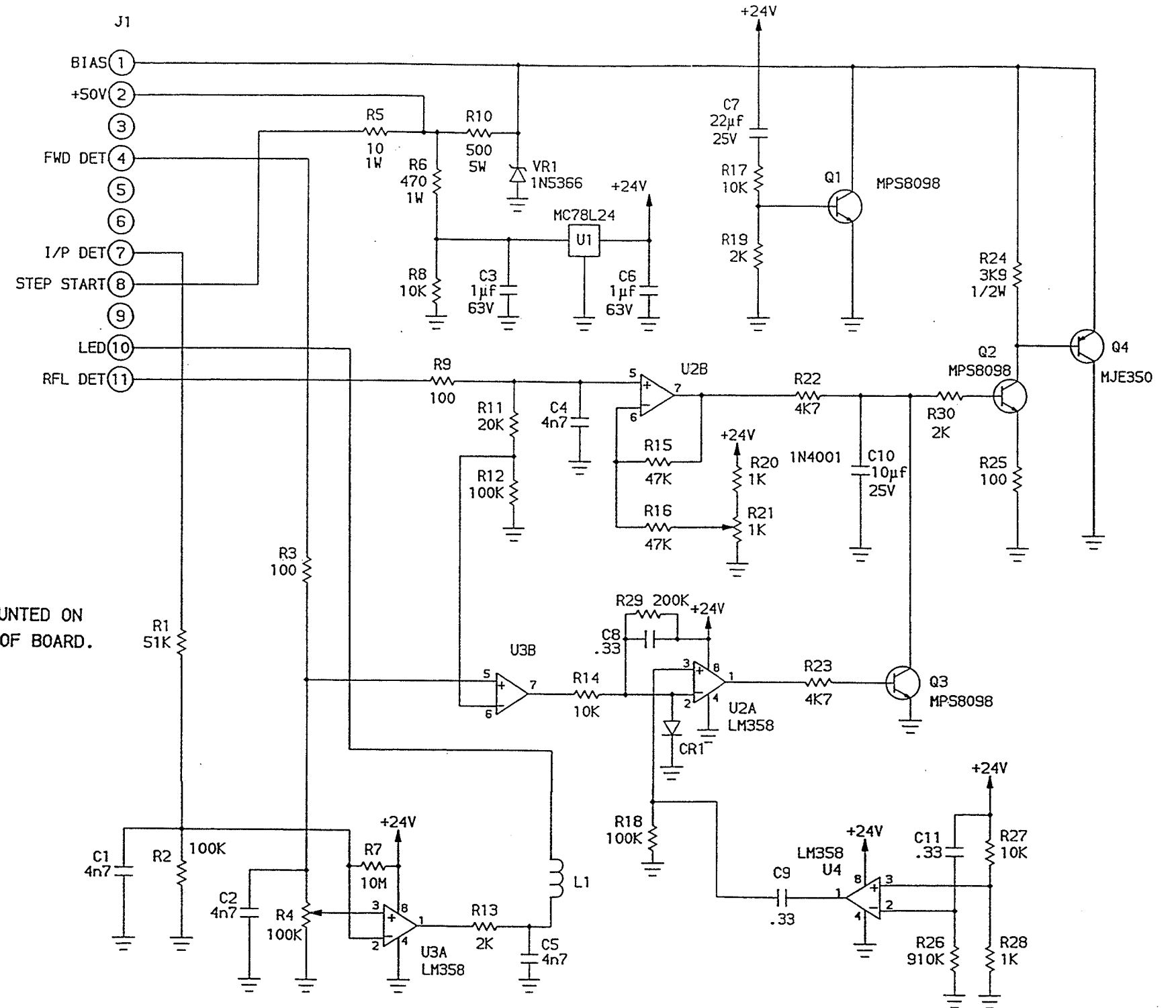

SOLDER THESE 2 SPACERS
UNDERSIDE ONLY.
DO NOT SOLDER
OTHER 2 SPACERS.

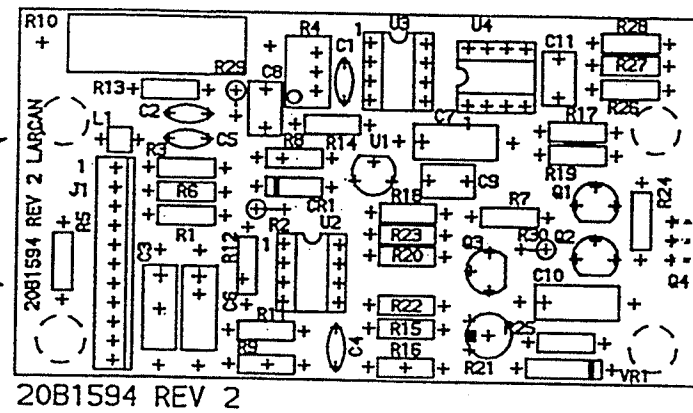

NOTE-Q4 MOUNTED ON
UNDERSIDE OF BOARD.

RF MODULE OUTPUT VSWR CONTROL BOARD:
Assembly Ref Dwg: 20B1594 sht 1 rev 2,
Schematic Ref Dwg: 30C1418 sht 1 rev 6,